

# W. R. Long Live 3rd Function Valve Kit



Scan Me  
Valve Kit FAQs

## I. Electrical Instructions for the Live 3rd Function Valve Kit

1. If you are using the factory handle proceed directly to section II "Factory Handle Instructions" below.
2. Remove the knob from your joystick and unpack the provided handle from its box.
3. The handle comes pre-assembled with two black cables. One cable is a red wire that will run to your power source. The other cable is two control wires that will run to the connection block on the valve.
4. Back out the set screws and place the W. R. Long handle over the joystick rod. Be sure to leave the button head bolt installed as it is used to secure the back of the handle and prevent the bottom of the switches from touching the top of the joystick. Adjust the handle orientation as necessary according to your preference and tighten down the set screws and lock nuts.
5. Run the black cable with the 2 control wires from the W R Long Handle down to the valve. Plug in the connector on the end of the cable to the mating connector attached to the valve.
6. Connect the red wire from the handle to a hot wire on the tractor using the 10 amp in line fuse provided in the kit.
7. Test the valve by pressing one button at a time. If the attachment opens or closes opposite your preferred button you can switch the hoses on the back side of the bulkhead bracket.
8. Secure the cable runs to the joystick with a few tie wraps.

Please visit the Frequently Asked Questions (FAQ) page on our website. [www.wrlonginc.com](http://www.wrlonginc.com)

In many cases the valve kit installation instructions are written with the presumption that there is no backhoe attached to the tractor. The kit will work with a backhoe, however a new hydraulic hose may be required. Please call W. R. Long Inc. with any questions at 252-823-4570.

## II. Factory Handle Instructions

Some loaders come with a factory rocker switch or two push button switches to open and close a future attachment. The W. R. Long valve can be operated using the factory supplied switch(es) when there are relays included in the kit. Please confirm\* your kit includes relays before wiring directly to the factory switch(es). If you use your factory switch(es) make sure you completely disconnect the switch(es) from your tractor before connecting to the W. R. Long valve. See below for the control module to factory switch(es) wiring diagrams.

Wiring Diagram for Rocker Switch in Handle

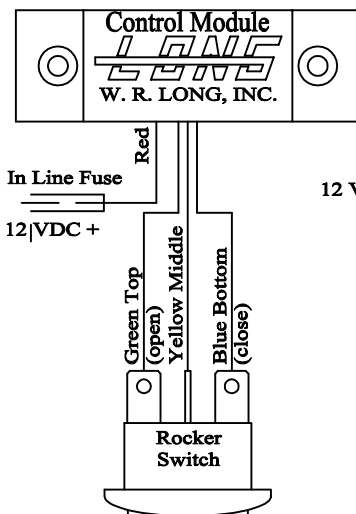

Wiring Diagram using two Push Buttons in Handle

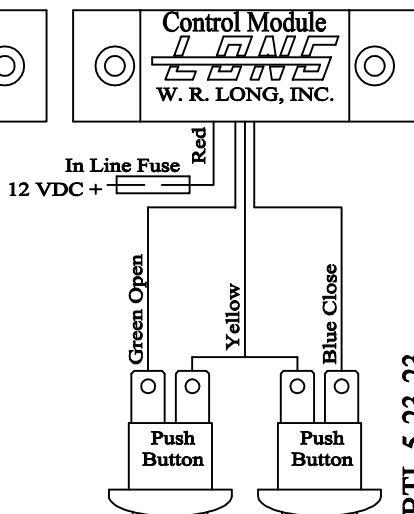

BTL 5-23-23

\*Kits that use relays have the red power wire running directly to the control module on the 3rd function valve. Kits that do not use relays have the red wire running directly to the handle.

## III. Flow Diagram

