

Selector Valve Kit (VKS18 and VKS30) (ST) Instructions

(ST) The Selector Valve is connected between the steel tubes and rubber hoses on the right loader arm.

1. Please visit our Frequently Asked Questions (FAQ) page on our website. www.wrlonginc.com.
2. Mount the W R Long Selector Valve on the right loader arm so that the **P1 and P2** ports are pointing up. The solenoid could be pointing toward the back of the tractor or toward the front depending on the valve that was provided. See sketch below.
3. Weld or bolt the bulk head bracket toward the right side of your torque tube. Make sure the quick connects point toward the back of the attachment.
4. On the left side of the right hand loader arm, there are four hoses that come from the loader valve which connect to four steel tubes. Mark one of the two hoses and steel tubes that are associated with the loader lift cylinders, so that the oil flow can be reconnected properly after the hoses have been disconnected. Disconnect the two hoses from the two steel tubes that are connected to the loader lift cylinders. Connect these two hoses to the P1 & P2 ports (top) on the selector valve. Using the two shorter hoses provided in the kit connect one end to the steel tubes and the other end to the C&D or C2&C3 ports (bottom) on the selector valve so that the oil flow is the same as before. Connect the two long hoses to the A&B or C1&C4 (side) ports on the selector valve and connect the other end to the back of the bulkhead plate.
5. Remove the knob from the joystick and install the W R Long handle with the red push button. Connect the red wire on the hand grip to a hot wire on the tractor using the 10 amp inline fuse.
6. Your valve may already have 2 blue wires attached. If so, then connect one blue wire from the valve to the black wire from the handle. It does not matter which blue wire you use. Connect the other blue wire to ground. Otherwise see below for valve wiring diagram.
7. If your tractor has a cab, check to make sure that the selector valve or bracket does not hit the cab when the loader arm is all the way up.
8. Once installation is complete, verify that ALL fittings and hose connections are tight. Carefully operate your new W. R. Long valve to check for leaks. Next, slowly operate your loader and attachment functions

(up-down, dump-curl, open-close), through the full range of motion, to check for hose clearance or binding.

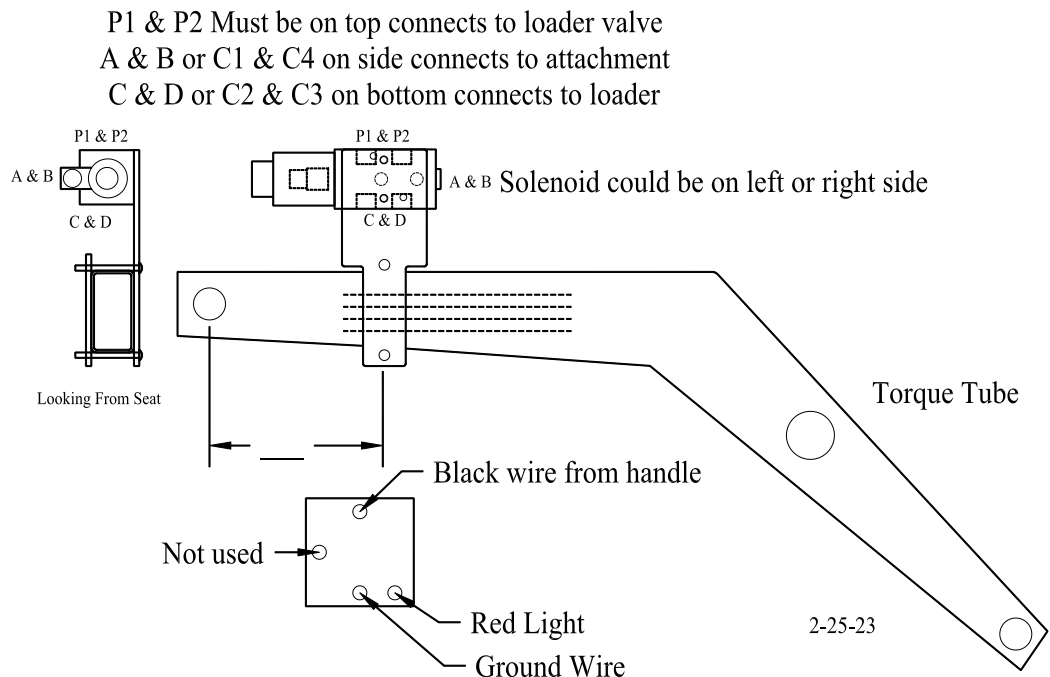

Selector Valve Kit (VKS18 and VKS30) (QC) Instructions

(QC) The Selector Valve is connected to the quick connects between the loader and tractor.

1. Please visit our Frequently Asked Questions (FAQ) page on our website. www.wrlonginc.com.
2. Mount the W R Long Selector Valve on the right loader arm so that the **P1 and P2** ports are pointing up. The solenoid could be pointing toward the back of the tractor or toward the front depending on the valve that was provided. See sketch below.
3. Weld or bolt the bulkhead bracket toward the right side of your torque tube. Make sure the quick connects point toward the back of the attachment.
4. On the left side of the righthand loader arm, there are four hoses that come from the loader valve which connect to four steel tubes. Mark one of the two hoses and steel tubes that are associated with the loader lift cylinders, so that the oil flow can be reconnected properly after the hoses have been disconnected. Disconnect the two hoses from the two steel tubes that are connected to the loader lift cylinders. Connect these two hoses to the P1 & P2 ports (top) on the selector valve. Using the two shorter hoses provided in the kit connect one end to the steel tubes and the other end to the C&D or C2&C3 ports (bottom) on the selector valve so that the oil flow is the same as before. Connect the two long hoses to the A&B or C1&C4 (side) ports on the selector valve and connect the other end to the back of the bulkhead plate.
5. Remove the knob from the joystick and install the W R Long handle with the red push button. Connect the red wire on the hand grip to a hot wire on the tractor using the 10 amp inline fuse.
6. Your valve may already have 2 blue wires attached. If so, then connect one blue wire from the valve to the black wire from the handle. It does not matter which blue wire you use. Connect the other blue wire to ground. Otherwise see below for valve wiring diagram.
7. If your tractor has a cab, check to make sure that the selector valve or bracket does not hit the cab when the loader arm is all the way up.
8. Once installation is complete, verify that ALL fittings and hose connections are tight. Carefully operate your new W. R. Long valve to check for leaks. Next, slowly operate your loader and attachment functions

(up-down, dump-curl, open-close), through the full range of motion, to check for hose clearance or binding.

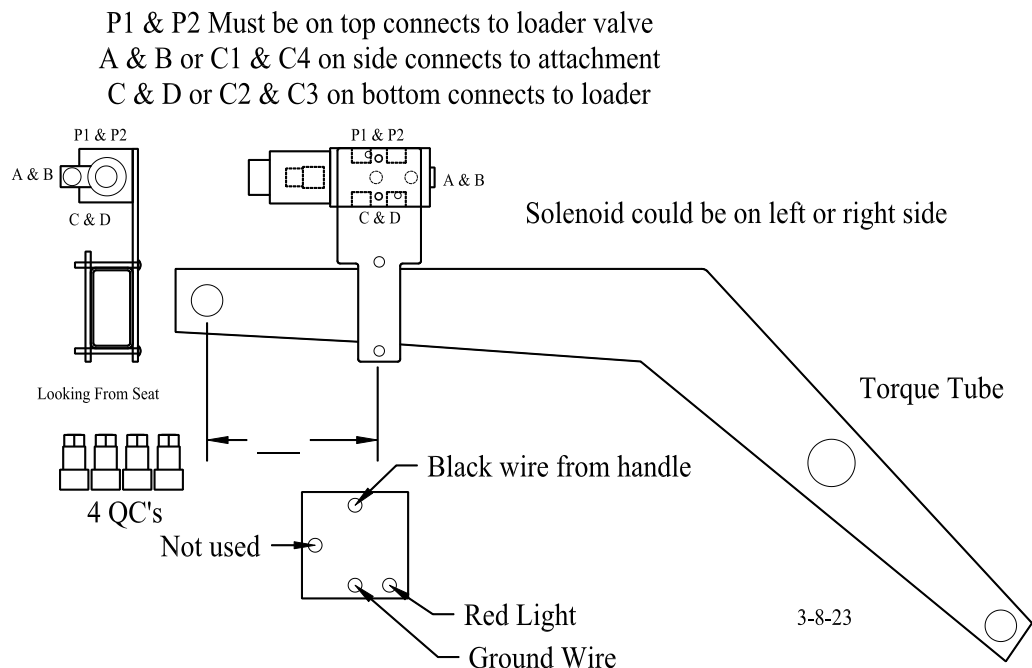

Selector Valve Kit (VKS18 and VKS30) (TT) Torque Tube Instructions

(TT) The Selector Valve is connected to the Tee's next to the Torque Tube.

1. Please visit our Frequently Asked Questions (FAQ) page on our website. www.wrlonginc.com.
2. Mount the W R Long Selector Valve on the right loader arm so that the **P1 and P2** ports are pointing up. The solenoid could be pointing toward the back of the tractor or toward the front depending on the valve that was provided. See sketch below.
3. Weld or bolt the bulkhead bracket toward the right side of your torque tube. Make sure the quick connects point toward the back of the attachment.
4. On the left side of the righthand loader arm, there are four hoses that come from the loader valve and connect onto four "Tees" near the torque tube on your loader. Mark one set of the two hoses that are associated with the loader lift cylinders, so that the oil flow can be reconnected properly after the hoses have been disconnected. Disconnect the two hoses from the two "Tees" that connect the loader lift cylinders to the loader valve. Connect these two hoses to the P1 & P2 ports (top) on the selector valve. Using the two shorter hoses provided in the kit connect one end to the "Tees" and the other end to the C&D or C2&C3 ports (bottom) on the selector valve so that the oil flow is the same as before. Connect the two long hoses to the A&B or C1&C4 (side) ports on the selector valve and connect the other end to the back of the bulkhead plate.
5. Remove the knob from the joystick and install the W R Long handle with the red push button. Connect the red wire on the hand grip to a hot wire on the tractor using the 10 amp inline fuse.
6. Your valve may already have 2 blue wires attached. If so, then connect one blue wire from the valve to the black wire from the handle. It does not matter which blue wire you use. Connect the other blue wire to ground. Otherwise see below for valve wiring diagram.
7. If your tractor has a cab, check to make sure that the selector valve or bracket does not hit the cab when the loader arm is all the way up.
8. Once installation is complete, verify that ALL fittings and hose connections are tight. Carefully operate your new W. R. Long valve to check for leaks. Next, slowly operate your loader and attachment functions

(up-down, dump-curl, open-close), through the full range of motion, to check for hose clearance or binding.

P1 & P2 Must be on top connects to loader valve
 A & B or C1 & C4 on side connects to attachment
 C & D or C2 & C3 on bottom connects to loader

